

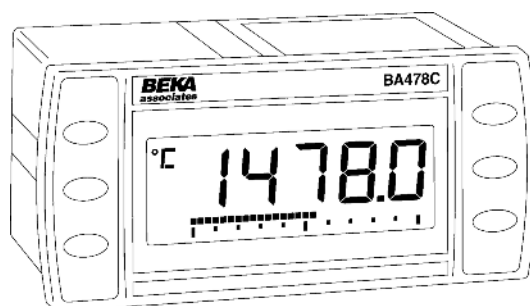

BA47X/67X Indicating Temperature Transmitter

HART Interface Guide

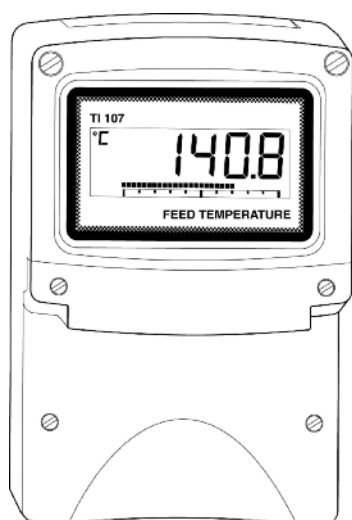

This guide applies to the following models:

BA47X/67X Series Indicating Temperature Transmitters

BA478C - *Panel mounted, Intrinsically Safe*

BA474D - *Field mounted, Intrinsically Safe*

BA474ND - *Field mounted, Type nL*

BA678C - *Panel mounted, Safe Area*

BA674D - *Field mounted, Safe Area*

Contents

1. Introduction	5
1.1 <i>Scope</i>	5
1.2 <i>Purpose</i>	5
1.3 <i>Who should use this document?</i>	5
1.4 <i>Abbreviations and definitions</i>	5
1.5 <i>References</i>	5
2. Device Identification	6
3. Product Overview	6
4. Product Interfaces	7
4.1 <i>Process Interface</i>	7
4.1.1 <i>Sensor Input Channels</i>	7
4.2 <i>Host Interface</i>	7
4.2.1 <i>Analogue Output</i>	7
4.2.2 <i>Alarm Outputs</i>	7
4.3 <i>Local Interfaces and Controls</i>	8
4.3.1 <i>Display</i>	8
4.3.2 <i>Keypad</i>	8
5. Device Variables	9
6. Dynamic Variables	9
7. Status Information	9
7.1 <i>Device Status</i>	9
7.2 <i>Extended Device Status</i>	9
7.3 <i>Additional Device Status</i>	10
8. Universal Commands	12
9. Common-Practice Commands	12
9.1 <i>Supported Commands</i>	12
9.2 <i>Burst Mode</i>	12
9.3 <i>Catch Device Variable</i>	12
10. Device-Specific Commands	13
10.1 <i>Command #128: Reset to defaults</i>	14
10.2 <i>Command #129: Read Bargraph Settings</i>	14
10.3 <i>Command #130: Write Bargraph Settings</i>	15
10.4 <i>Command #131: Read Number of Display Decimal Places</i>	16
10.5 <i>Command #132: Write Number of Display Decimal Places</i>	17
10.6 <i>Command #133: Read Display Scaling</i>	18
10.7 <i>Command #134: Write Display Scaling</i>	18
10.8 <i>Command #136: Remove Primary Variable Zero Offset</i>	19
10.9 <i>Command #138: Read Custom Linearisation</i>	20
10.10 <i>Command #139: Write Custom Linearisation</i>	21
10.11 <i>Command #140: Inhibit Diagnostics</i>	23
10.12 <i>Command #141: Read Output Status</i>	23
10.13 <i>Command #142: Write Output Status</i>	24
10.14 <i>Command #143: Read Key Status</i>	25
10.15 <i>Command #144: Read Alarm Settings</i>	26
10.16 <i>Command #145: Write Alarm Settings</i>	27
10.17 <i>Command #146: Get Fault / Burnout Action</i>	29
10.18 <i>Command #147: Set Fault / Burnout Action</i>	30
10.19 <i>Command #148: Get Product ID</i>	31
10.20 <i>Command #149: Read Transfer Function</i>	31
10.21 <i>Command #150: Set Transfer Function</i>	32
10.22 <i>Command #151: Read RTD Probe Connection</i>	33
10.23 <i>Command #152: Write RTD Probe Connection</i>	34
10.24 <i>Command #153: Read Security Code</i>	35
10.25 <i>Command #154: Write Security Code</i>	36
10.26 <i>Command #155: Read Temperature Status</i>	37
10.27 <i>Command #156: Read Temperature Configuration</i>	38
10.28 <i>Command #157: Read Thermocouple Configuration</i>	39

10.29 Command #158: Read Callendar-Van Dusen Coefficients	40
10.30 Command #159: Write Temperature Probe Type	41
10.31 Command #162: Select Cold Junction Compensation Type.....	42
10.32 Command #163: Write Manual Cold Junction Temperature.....	43
10.33 Command #164: Write Manual Cold Junction Temperature.....	44
11 Tables.....	45
Table 1. Temperature Device Variable Status.....	45
Table 2. Temperature Status 0.....	45
Table 3. Temperature Probe Types.....	45
Table 4. Thermocouple Probe Connections	45
Table 5. Thermocouple Cold Junction Compensation.....	45
Table 6. Temperature Standards.....	45
Unit Conversion	45
12. Performance	46
12.1 Sampling Rates.....	46
12.2 Power-Up.....	46
12.3 Reset.....	46
12.4 Self-Test.....	46
12.5 Command Response Times	47
12.6 Busy and Delayed-Response	47
12.7 Long Messages	47
12.8 Non-Volatile Memory.....	47
12.9 Modes.....	47
12.10 Write Protection.....	47
12.11 Damping	47
Annex A. Capability Checklist.....	48
Annex B. Default Configuration.....	48
Annex C. Revision History	49

1. INTRODUCTION

1.1 Scope

The following instruments manufactured by BEKA associates comply with HART Protocol Revision 7 :

BA478C - Panel mounted, Intrinsically Safe, Indicating Temperature Transmitter
BA474D - Field mounted, Intrinsically Safe, Indicating Temperature Transmitter
BA474ND - Field mounted, Type nL, Indicating Temperature Transmitter
BA678C - Panel mounted, Safe Area, Indicating Temperature Transmitter
BA674D - Field mounted, Safe Area, Indicating Temperature Transmitter

This document specifies all the device specific features and documents HART Protocol implementation details (e.g., the Engineering Unit Codes supported). The functionality of this Field Device is described sufficiently to allow its proper application in a process and its complete support in HART capable Host Applications.

1.2 Purpose

This specification is designed to compliment other documentation (e.g., the relevant Instruction Manual) by providing a complete, unambiguous description of this Field Device from a HART Communication perspective

1.3 Who should use this document?

The specification is designed to be a technical reference for HART capable Host Application Developers, System Integrators and knowledgeable End Users. It also provides functional specifications (e.g., commands, enumerations and performance requirements) used during Field Device development, maintenance and testing. This document assumes the reader is familiar with HART Protocol requirements and terminology.

1.4 Abbreviations and definitions

PV	Primary Variable
SV	Secondary Variable
ADC	Analogue to Digital Converter
CPU	Central Processing Unit
DAC	Digital to Analogue Converter
EEPROM	Electrically-Erasable Read-Only Memory
Pt100	100-ohm Platinum (temperature sensor)
ROM	Read-Only Memory
RTD	Resistance Temperature Detector

1.5 References

HART Smart Communications Protocol Specification. HCF_SPEC-13. Available from the Hart Communication Foundation (www.hartcomm.org).

Our website at www.beka.co.uk is kept up to date with the latest literature and information such as instruction manuals and device files.

After reading through this guide, if you still have a problem getting the results you need then email us at support@beka.co.uk and we will do our best to help you

2. DEVICE IDENTIFICATION

Manufacturer Name:	BEKA associates	Model Name(s):	BA47X/67X SERIES
Manufacture ID Code:	24615 6027 Hex	Device Type Code:	57540 E0C4 Hex
HART Protocol Revision	7.2	Device Revision:	1
Number of Device Variables	2		
Physical Layers Supported	FSK		
Physical Device Category	Transmitter		

The BA47X/67X series of temperature transmitters are designed to be mounted in industrial environments. The name plate is located on the top of the instrument and indicates the model name. The device revision is shown on the screen when the P + ▼ keys are pressed. (see section 4.3.2).

3. PRODUCT OVERVIEW

The BA47X/67X series are 4/20mA loop powered temperature transmitters with large easy to read displays. The instruments may be conditioned on-site to operate with most common thermocouples and resistance thermometers and will provide a linear 4/20mA output proportional to temperature, plus a digital temperature display. Voltage and resistance inputs may be scaled allowing the instruments to display variables other than temperature such as position and weight.

Optional factory fitted alarms provide two galvanically isolated solid state outputs that may be independently configured for high or low operation.

For installation in poorly illuminated areas, an optional factory fitted loop powered display backlight is available.

The models in the BA47X/67X series are functionally identical, but are either field or panel mounting for use in either safe or hazardous areas. Refer to the individual product datasheets for full details.

As an example, the BA474D has been certified intrinsically safe and as associated apparatus by European Notified Body Intertek Testing and Certification Ltd (ITS). The transmitter complies with the ATEX Directive 94/9/EC for use in explosive gas and combustible dust atmospheres. ATEX dust certification is an option.

For international applications the BA474D has IECEx intrinsic safety and associated apparatus certification for use in explosive gas and combustible dust atmospheres. IECEx dust certification is an option.

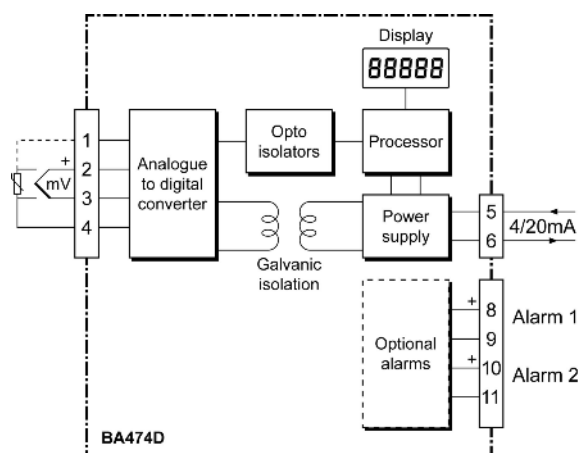

4. PRODUCT INTERFACES

4.1 Process Interface

4.1.1 Sensor Input Channels

The main temperature sensor ("external sensor") input provides four terminals, marked 1, 2, 3 and 4, for connection of two-, three- or four-wire RTD sensors, or for two wires from a thermocouple. Refer to the Installation Manual for connection details. Operating ranges correspond to the capabilities of each sensor type.

The transmitter input may be configured to measure resistance for non-temperature measurements such as weight or position.

The transmitter input may also be connected directly to a voltage source for other non-standard applications.

An additional internal temperature sensor is mounted near the sensor terminals. This provides cold junction compensation when a thermocouple is used as the main sensor.

4.2 Host Interface

4.2.1 Analogue Output

The 2-wire 4/20mA current loop is connected on two terminals marked 5 and 6. Refer to the Installation Manual for connection details.

This output from the transmitter represents the process temperature measurement, linearised and scaled according to the configured range of the instrument. This output corresponds to the Primary Variable. HART Communication is supported on this loop. This device has a CN number of 1.

A guaranteed linear over-range is provided. Device malfunction can be indicated by down-scale or up-scale current. The direction is selectable by the user; refer to the Installation Manual for details. Current values are shown in the table below.

	Direction	Values (percent of range)	Values (mA or V)
Linear over-range	Down	-1.25% ± 0.2%	3.768 to 3.832 mA
	Up	+103.125% ± 0.2%	20.468 to 20.532 mA
Device malfunction indication	Down: less than	Selectable between: -2.5% -1.25% or off	3.6 mA 3.8mA
	Up: greater than	Selectable between: +106.25% or off	21.00 mA
Maximum current		+106.45%	21.032 mA
Multi-Drop current draw			4.0 mA
Lift-off voltage (without backlight)			9.0 V
Lift-off voltage (with backlight)			15.5 V

4.2.2 Alarm Outputs

As an optional accessory (available only at the time of ordering), the transmitter can be fitted with two solid state outputs. These are totally isolated and can be energised or de-energised independently of each other. They are driven by alarm set-point values that can be assigned so that they operate automatically. Note that they are not intended to be used as control outputs and should be used for indication only. Refer to the Installation Manual for full details.

Each alarm has a galvanically isolated single pole solid state switch output. Each output is polarised and current will only flow in one direction. Terminals 8 and 10 should be connected to the positive side of the supply.

Ron = 5ohms + 0.6V
Roff = greater than 180k

Note: Because of the series protection diode some test meters may not detect a closed alarm output.

4.3 Local Interfaces and Controls

4.3.1 Display

The LCD display is made up of five 20mm high digits which can display values from -99999 to 99999. Annunciators can be programmed to display °C or °F.

There is a 31 digit bargraph that can be scaled to graphically show the measurement range of interest.

Two further annunciators show if the optional alarm setpoints have been reached.

The display may optionally be backlit by an ultra-efficient green LED module which enables the screen to be viewed in all conditions, from bright sunlight to total darkness.

4.3.2 Keypad

All main functions of the transmitter may be configured via the front panel push buttons. Buttons respond within 0.5 seconds of being operated and unless continuously pushed the transmitter display will return to the operating mode after 60 seconds.

In the operational mode, i.e. when the transmitter is displaying the input signal, these push buttons have the following functions:

Button	Function
▼	While this button is operated the transmitter will show the display corresponding to 4mA output.
▲	While this button is operated the transmitter will show the display corresponding to 20mA output.
▼ + ▲	Transmitter displays output current in mA followed by output as % of the range.
P + ▼	Transmitter displays HART® short address, followed by firmware version number, followed by Device Revision.
P + E	Entry to configuration menu.
E	Enables a response to the "Find Device" command #73

When fitted with optional alarms:

P + ▲	Entry to alarm set point menu (if enabled).
E + ▲	Transmitter displays alarm 1 setpoint
E + ▼	Transmitter displays alarm 2 setpoint
P	Activated alarm reverts to the non-alarm condition for the configured alarm silence time.

5. DEVICE VARIABLES

The device exposes two device variables to allow the support of command 9 and 33 only.

6. DYNAMIC VARIABLES

Two dynamic variables are implemented; PV – Primary Variable and SV – Secondary Variable

	Meaning	Units
PV	Reading of external sensor	degC, degF, degR, Kelvin, mV, V, Ohms
SV	Temperature of cold-junction sensor	degC, degF, degR, Kelvin

For RTD sensors, the PV is derived from the sensor's resistance, using a polynomial equation. For thermocouples, the PV is derived from the millivolt input signal, using polynomials, with compensation for the cold junction temperature.

The SV is available in either case.

The PV is smoothed, and the damping can be set using command #34.

7. STATUS INFORMATION

7.1 Device Status

Bit 4 ("More Status Available") is set whenever any failure is detected. Command #48 gives further detail.

Bit 1 ("Non-Primary Variable Out Of Limits") refers to the internal cold-junction temperature sensor.

7.2 Extended Device Status

The Field Device does not provide any extended status, and always returns a zero.

7.3 Additional Device Status

Command #48 returns 3 bytes of data, with the following status information:

Byte	Value	Meaning	Class	Device Status Bits Set
0	Bit 0	RTD Resistance too high (Pt100 - >500R Pt1000 - >5000R)	Error	4
	Bit 1	RTD Short (Pt100 - <5R Pt1000 - <50R)	Error	4
	Bit 2	Resistance Input too high (>5000R)	Error	4
	Bit 3	Voltage Input too high (>1.9 < -1.9 volts)	Error	4
	Bit 4	Sensor circuit supply voltage outside normal limits	Error	4
	Bit 5	THC burnout or bad sensor connection (>5000R)	Error	4
	Bit 6	RTD excitation current out of regulation	Error	4
	Bit 7	RTD input terminals high resistance (>50R)	Error	4
1	0	Alarm 1 Enabled and Inactive		
	1	Alarm 1 Enabled and Triggered (Setpoint exceeded, but in delay)		
	2	Alarm 1 Enabled and Active		
	3	Alarm 1 Enabled and Silenced		
	4	Alarm 1 Function Disabled		
	5-255	Undefined		
2	0	Alarm 2 Enabled and Inactive		
	1	Alarm 2 Enabled and Triggered (Setpoint exceeded, but in delay)		
	2	Alarm 2 Enabled and Active		
	3	Alarm 2 Enabled and Silenced		
	4	Alarm 2 Function Disabled		
	5-255	Undefined		
3	Bit 0	Non-volatile memory checksum failure during self test		
	Bit 1	Button pressed or stuck during self test		
	Bit 2	Warning of intermittent inter-processor communications problem. Set before the device malfunction bit is set.		

Byte 0 Sensor status:

The Additional Status Available bit is set on ANY change

Bits 0 to 3 take up to 1 second to action or clear

Bits 4 to 7 take up to 10 seconds to action or clear

Sensor 'faults' in voltage and resistance inputs do NOT trigger display or loop current fault indication

Byte 1 Alarm 1 Status:

Additional status available bit set on transition from Triggered to Active only (i.e. Enum 1 -> 2)

Byte 2 Alarm 2 Status:

Additional status available bit set on transition from Triggered to Active only (i.e. Enum 1 -> 2)

Byte 3 Diagnostic Status

Bits 0 to 1 are only set during self test

Bit 2 can be set at any time

"Not used" bits are always set to 0.

These bits are set or cleared by the self-test executed at power up, or following a reset or self-test command. They are also changed by any failure detected during continuous background self-testing.

8. UNIVERSAL COMMANDS

Command #3 returns the loop current, PV and SV (A total of 14 bytes of response data).

9. COMMON-PRACTICE COMMANDS

9.1 Supported Commands

The following common-practice commands are implemented:

Command	Description
33	Read Device Variables
34	Write Primary Variable Damping Value
35	Write Primary Variable Range Values
36	Set Primary Variable Upper Range Value
37	Set Primary Variable Lower Range Value
40	Enter/Exit Fixed Current Mode
41	Perform Device Self-Test
42	Perform Master Reset
43	Set Primary Variable Zero
44	Write Primary Variable Units
45	Trim Loop Current Zero
46	Trim Loop Current Gain
49	Write Primary Variable Transducer Serial Number
59	Write Number Of Response Preambles
71	Lock Device
72	Squawk
73	Find Device (Armed by pressing and holding the 'E' key while the command is issued)
76	Read Lock Device State
95	Read Device Communications Statistics

9.2 Burst Mode

This Field Device does not support Burst Mode.

9.3 Catch Device Variable

This Field Device does not support Catch Device Variable.

10. DEVICE-SPECIFIC COMMANDS

The following device-specific commands are implemented:

Command	Description
128	Reset to defaults
129	Read Bargraph Settings
130	Write Bargraph Settings
131	Read Number of Display DPs
132	Write Number of Display DPs
133	Read Display Scaling
134	Write Display Scaling
135	Reserved
136	Remove PV Zero Offset
137	Reserved
138	Read Custom Linearisation
139	Write Custom Linearisation
140	Inhibit Diagnostics
141	Read Output status
142	Write Output status
143	Read key status
144	Read alarm settings
145	Write alarm settings
146	Get Fault / Burnout Action
147	Set Fault / Burnout Action
148	Get Product ID
149	Read Transfer Fn
150	Set Transfer Fn
151	Read RTD Probe Connection
152	Write RTD Probe Connection
153	Read Security ID
154	Write Security ID
155	Read Temperature Status
156	Read Temperature Configuration
157	Read Thermocouple Configuration
158	Read Call Van Dusen Coefficients
159	Write Temperature Probe Type
160	Reserved
161	Reserved
162	Select Cold Junction Compensation Type
163	Write Manual Cold Junction Temperature
164	Write Call Van Dusen Coefficients

10.1 Command #128: Reset to defaults

This command restores the device configuration to what it was when it left the factory.

Request Data Bytes

Byte	Format	Description
0	Enum	1 = Reset

Response Data Bytes

Byte	Format	Description
0	Enum	1 = Reset

Command-Specific Response Codes

Code	Class	Description
0	Success	No Command-Specific Errors
1		Undefined
2	Error	Invalid Selection
3-6		Undefined
7	Error	In Write Protect Mode
8-15		Undefined
16	Error	Access Restricted
17-35		Undefined
36	Error	Delayed Response Conflict
37-127		Undefined

10.2 Command #129: Read Bargraph Settings

This command reads the properties of the display bargraph.

Request Data Bytes

Byte	Format	Description
None		

Response Data Bytes

Byte	Format	Description
0	Enum	Bar Type: 0 = No Bar 1 = Left align 2 = Centre align 3 = Right align
1-4	Float	Bar Min
5-8	Float	Bar Max

Command-Specific Response Codes

Code	Class	Description
0	Success	No Command-Specific Errors
1-127		Undefined

10.3 Command #130: Write Bargraph Settings

This command configures the properties of the display bargraph..

Request Data Bytes

Byte	Format	Description
0	Enum	Bar Type: 0 = No Bar 1 = Left align 2 = Centre align 3 = Right align
1-4	Float	Bar Min
5-8	Float	Bar Max

Response Data Bytes

Byte	Format	Description
0	Enum	Bar Type: 0 = No Bar 1 = Left align 2 = Centre align 3 = Right align
1-4	Float	Bar Min
5-8	Float	Bar Max

Command-Specific Response Codes

Code	Class	Description
0	Success	No Command-Specific Errors
1		Undefined
2	Error	Invalid Selection
3-4		Undefined
5	Error	Too Few Data Bytes Received
6		Undefined
7	Error	In Write Protect Mode
8-15		Undefined
16	Error	Access Restricted
17-35		Undefined
36	Error	Delayed Response Conflict
37-127		Undefined

10.4 Command #131: Read Number of Display Decimal Places

This command reads the number of decimal points displayed.

Request Data Bytes

Byte	Format	Description
None		

Response Data Bytes

Byte	Format	Description
0	Unsigned-8	Number of decimal places displayed in non-temperature modes
1	Unsigned-8	Number of decimal places displayed in temperature modes

Note: Value of byte 0 is in the range 0 to 5, where 0-4 is the number of places and 5 is "Auto"
Value of byte 1 is in the range 0 to 1, where 0-1 is the number of places

Command-Specific Response Codes

Code	Class	Description
0	Success	No Command-Specific Errors
1-127		Undefined

10.5 Command #132: Write Number of Display Decimal Places

This command sets the number of decimal places displayed. When the unit is configured to display temperatures, the allowed range is limited to a maximum of 1 decimal place.

Request Data Bytes

Byte	Format	Description
0	Unsigned-8	Number of decimal places displayed in non-temperature modes
1	Unsigned-8	Number of decimal places displayed in temperature modes

Note: Value of byte 0 is in the range 0 to 5, where 0-4 is the number of places and 5 is "Auto"
Value of byte 1 is in the range 0 to 1, where 0-1 is the number of places

Response Data Bytes

Byte	Format	Description
0	Unsigned-8	Number of decimal places displayed in non-temperature modes
1	Unsigned-8	Number of decimal places displayed in temperature modes

Note: Value of byte 0 is in the range 0 to 5, where 0-4 is the number of places and 5 is "Auto"
Value of byte 1 is in the range 0 to 1, where 0-1 is the number of places

Command-Specific Response Codes

Code	Class	Description
0	Success	No Command-Specific Errors
1		Undefined
2	Error	Invalid Selection
3-4		Undefined
5	Error	Too Few Data Bytes Received
6		Undefined
7	Error	In Write Protect Mode
8-15		Undefined
16	Error	Access Restricted
17-35		Undefined
36	Error	Delayed Response Conflict
37-127		Undefined

10.6 Command #133: Read Display Scaling

This command reads the current scaling applied to the PV (device variable 0) prior to display on the LCD. Default is gain = 1.0 and offset = 0.0 so that the LCD shows the PV.

Request Data Bytes

Byte	Format	Description
None		

Response Data Bytes

Byte	Format	Description
0-3	Float	Offset
4-7	Float	Gain

Command-Specific Response Codes

Code	Class	Description
0	Success	No Command-Specific Errors
1-127		Undefined

10.7 Command #134: Write Display Scaling

This command allows a user to apply a simple linear scaling to the value on the LCD display.

Request Data Bytes

Byte	Format	Description
0-3	Float	Offset
4-7	Float	Gain

Response Data Bytes

Byte	Format	Description
0-3	Float	Offset
4-7	Float	Gain

Command-Specific Response Codes

Code	Class	Description
0	Success	No Command-Specific Errors
1-4		Undefined
5	Error	Too Few Data Bytes Received
6		Undefined
7	Error	In Write Protect Mode
8-15		Undefined
16	Error	Access Restricted
17-35		Undefined
36	Error	Delayed Response Conflict
37-127		Undefined

10.8 Command #136: Remove Primary Variable Zero Offset

This command removes the zero offset applied to the PV by command #43 (Set Primary Variable Zero Offset)

Request Data Bytes

Byte	Format	Description
0	Enum	1 = Remove offset

Response Data Bytes

Byte	Format	Description
0	Enum	1 = Remove offset

Command-Specific Response Codes

Code	Class	Description
0	Success	No Command-Specific Errors
1-5		Undefined
6	Error	Device Specific Command Error
7	Error	In Write Protect Mode
8-15		Undefined
16	Error	Access Restricted
17-35		Undefined
36	Error	Delayed Response Conflict
37-127		Undefined

10.9 Command #138: Read Custom Linearisation

This command reads the configuration of the 16 point lineariser that is applied to Device Variable 0 to get the PV. The loop current and displayed value are derived from the PV.

Request Data Bytes

Byte	Format	Description
0	Unsigned-8	Block number = N [Value must be the range 0 to 3]

Response Data Bytes

Byte	Format	Description
0	Unsigned-8	Block number = N [Value must be the range 0 to 3]
1	Enum	Active Point 0 = Inactive 1 = Active
2-5	Float	Input value A
6-9	Float	Linearised value A
10	Enum	Active Point 0 = Inactive 1 = Active
11-14	Float	Input value B
15-18	Float	Linearised value B
19	Enum	Active Point 0 = Inactive 1 = Active
20-23	Float	Input value C
24-27	Float	Linearised value C
28	Enum	Active Point 0 = Inactive 1 = Active
29-32	Float	Input value D
33-36	Float	Linearised value D

Command-Specific Response Codes

Code	Class	Description
0	Success	No Command-Specific Errors
1		Undefined
2	Error	Invalid Selection
3-4		Undefined
5	Error	Too Few Data Bytes Received
6-127		Undefined

10.10 Command #139: Write Custom Linearisation

This command allows a user to apply piecewise linear scaling to Device Variable 0 to compensate for non-linear inputs.

Request Data Bytes

Byte	Format	Description
0	Unsigned-8	Block number = N [Value must be the range 0 to 3]
1	Enum	Active Point 0 = Inactive 1 = Active
2-5	Float	Input value A
6-9	Float	Linearised value A
10	Enum	Active Point 0 = Inactive 1 = Active
11-14	Float	Input value B
15-18	Float	Linearised value B
19	Enum	Active Point 0 = Inactive 1 = Active
20-23	Float	Input value C
24-27	Float	Linearised value C
28	Enum	Active Point 0 = Inactive 1 = Active
29-32	Float	Input value D
33-36	Float	Linearised value D

Response Data Bytes

Byte	Format	Description
0	Unsigned-8	Block number = N [Value must be the range 0 to 3]
1	Enum	Active Point 0 = Inactive 1 = Active
2-5	Float	Input value A
6-9	Float	Linearised value A
10	Enum	Active Point 0 = Inactive 1 = Active
11-14	Float	Input value B
15-18	Float	Linearised value B
19	Enum	Active Point 0 = Inactive 1 = Active
20-23	Float	Input value C
24-27	Float	Linearised value C
28	Enum	Active Point 0 = Inactive 1 = Active
29-32	Float	Input value D
33-36	Float	Linearised value D

Command-Specific Response Codes

Code	Class	Description
0	Success	No Command-Specific Errors
1		Undefined
2	Error	Invalid Selection
3-4		Undefined
5	Error	Too Few Data Bytes Received
6	Error	Device Specific Command Error
7	Error	In Write Protect Mode
8-15		Undefined
16	Error	Access Restricted
17-31		Undefined
32	Error	Busy
33	Error	Delayed Response Initiated
34	Error	Delayed Response Running
35-127		Undefined

10.11 Command #140: Inhibit Diagnostics

Sensor Diagnostics may cause errors when an intelligent calibrator is used to configure the unit. This command allows a user to temporarily turn off the diagnostics to avoid such problems. It can only be cancelled by a restart.

Request Data Bytes

Byte	Format	Description
0	Enum	1 = Inhibit Diagnostics

Response Data Bytes

Byte	Format	Description
0	Enum	1 = Inhibit Diagnostics

Command-Specific Response Codes

Code	Class	Description
0	Success	No Command-Specific Errors
1-5		Undefined
6	Error	Device Specific Command Error
7	Error	In Write Protect Mode
8-15		Undefined
16	Error	Access Restricted
17-35		Undefined
36	Error	Delayed Response Conflict
37-127		Undefined

10.12 Command #141: Read Output Status

This command allows a remote user to interrogate the status of the alarm card contacts (if fitted).

Request Data Bytes

Byte	Format	Description
None		

Response Data Bytes

Byte	Format	Description
0	Bits	Output status: [Bit set = Output On] 0 = Output 1 1 = Output 2 2 –6 : Undefined 7 = Bit set if no alarms fitted

Command-Specific Response Codes

Code	Class	Description
0	Success	No Command-Specific Errors
1-127		Undefined

10.13 Command #142: Write Output Status

This command allows a remote user to control the alarm card contacts directly (if fitted). This feature is not available when any internal alarms have been configured.

Request Data Bytes

Byte	Format	Description
0	Bits	Output status: [Bit set = Output On] 0 = Output 1 1 = Output 2

Response Data Bytes

Byte	Format	Description
0	Bits	Output status: [Bit set = Output On] 0 = Output 1 1 = Output 2

Command-Specific Response Codes

Code	Class	Description
0	Success	No Command-Specific Errors
1		Undefined
2	Error	Invalid Selection
3-4		Undefined
5	Error	Too Few Data Bytes Received
6	Error	Device Specific Command Error { <i>See note</i> }
7	Error	In Write Protect Mode
8-15		Undefined
16	Error	Access Restricted
17-35		Undefined
36	Error	Delayed Response Conflict
37-127		Undefined

Note : Returns an error if no alarms are fitted or any alarm is enabled

10.14 Command #143: Read Key Status

This command allows a remote user to detect if any keys have been pressed on the display. The stored key status is cleared when this command is actioned.

Request Data Bytes

Byte	Format	Description
None		

Response Data Bytes

Byte	Format	Description
0	Bits	Key status: [Bit set = Key pressed] 0 = P 1 = Down 2 = * 3 = # 4 = Up 5 = E

Command-Specific Response Codes

Code	Class	Description
0	Success	No Command-Specific Errors
1-127		Undefined

Note : The status is cleared when read.

10.15 Command #144: Read Alarm Settings

This command allows the properties of the two alarm card contacts to be read (if fitted).

Request Data Bytes

Byte	Format	Description
0	Enum	Alarm channel: 1 = Alarm 1 2 = Alarm 2

Response Data Bytes

Byte	Format	Description
0	Enum	Alarm channel: 1 = Alarm 1 2 = Alarm 2
1	Enum	Enable channel: 0 = Disabled 1 = Enabled
2-5	Float	Setpoint
6	Enum	Alarm type: 0 = Low alarm 1 = High alarm
7	Enum	Contact type: 0 = Normally closed 1 = Normally open
8-11	Float	Hysteresis
12-13	Unsigned-16	Delay time (Seconds) 0-3600
14-15	Unsigned-16	Silence time (Seconds) 0-3600
16	Enum	Status: 0 = Inactive 1 = Triggered 2 = Active 3 = Silenced 4 = Disabled

Command-Specific Response Codes

Code	Class	Description
0	Success	No Command-Specific Errors
1		Undefined
2	Error	Invalid Selection
3-4		Undefined
5	Error	Too Few Data Bytes Received
6-127		Undefined

10.16 Command #145: Write Alarm Settings

This command allows the properties of the two alarm card contacts to be configured (if fitted).

Request Data Bytes

Byte	Format	Description
0	Enum	Alarm channel: 0 = Alarm 1 1 = Alarm 2
1	Enum	Enable channel: 0 = Disabled 1 = Enabled
2-5	Float	Setpoint
6	Enum	Alarm type: 0 = Low alarm 1 = High alarm
7	Enum	Contact type: 0 = Normally closed 1 = Normally open
8-11	Float	Hysteresis
12-13	Unsigned-16	Delay time (Seconds) 0-3600
14-15	Unsigned-16	Silence time (Seconds) 0-3600

Response Data Bytes

Byte	Format	Description
0	Enum	Alarm channel: 0 = Alarm 1 1 = Alarm 2
1	Enum	Enable channel: 0 = Disabled 1 = Enabled
2-5	Float	Setpoint
6	Enum	Alarm type: 0 = Low alarm 1 = High alarm
7	Enum	Contact type: 0 = Normally closed 1 = Normally open
8-11	Float	Hysteresis
12-13	Unsigned-16	Delay time (Seconds) 0-3600
14-15	Unsigned-16	Silence time (Seconds) 0-3600

Command-Specific Response Codes

Code	Class	Description
0	Success	No Command-Specific Errors
1		Undefined
2	Error	Invalid Selection
3	Error	Passed Parameter Too Large
4		Undefined
5	Error	Too Few Data Bytes Received
6		Undefined
7	Error	In Write Protect Mode
8-15		Undefined
16	Error	Access Restricted
17-31		Undefined
32	Error	Busy
33	Error	Delayed Response Initiated
34	Error	Delayed Response Running
35-127		Undefined

10.17 Command #146: Get Fault / Burnout Action

This command reads the action applied to the analogue loop when a sensor fault is detected.
Only applicable to temperature inputs..

Request Data Bytes

Byte	Format	Description
None		

Response Data Bytes

Byte	Format	Description
0	Enum	Fault / Burnout action: 0 = Off 1 = Down 3.6mA 2 = Down 3.8mA 3 = Up 21mA

Command-Specific Response Codes

Code	Class	Description
0	Success	No Command-Specific Errors
1-127		Undefined

10.18 Command #147: Set Fault / Burnout Action

This command configures the action applied to the analogue loop when a sensor fault is detected. Only applicable to temperature inputs.

Request Data Bytes

Byte	Format	Description
0	Enum	Fault / Burnout action: 0 = Off 1 = Down 3.6mA 2 = Down 3.8mA 3 = Up 21mA

Response Data Bytes

Byte	Format	Description
0	Enum	Fault / Burnout action: 0 = Off 1 = Down 3.6mA 2 = Down 3.8mA 3 = Up 21mA

Command-Specific Response Codes

Code	Class	Description
0	Success	No Command-Specific Errors
1		Undefined
2	Error	Invalid Selection
3-4		Undefined
5	Error	Too Few Data Bytes Received
6		Undefined
7	Error	In Write Protect Mode
8-15		Undefined
16	Error	Access Restricted
17-35		Undefined
36	Error	Delayed Response Conflict
37-127		Undefined

10.19 Command #148: Get Product ID

This command allows a user to find the exact model number of an instrument and its options.

Request Data Bytes

Byte	Format	Description
None		

Response Data Bytes

Byte	Format	Description
0-29	Latin-1	Product ID e.g. BA474D-BL-ALM

Command-Specific Response Codes

Code	Class	Description
0	Success	No Command-Specific Errors
1-127		Undefined

10.20 Command #149: Read Transfer Function

This command shows if the 16 point lineariser is enabled or not.

See commands #138 & #139

Request Data Bytes

Byte	Format	Description
None		

Response Data Bytes

Byte	Format	Description
0	Enum	Linearisation: 0 = Linear 4 = Special Curve

Command-Specific Response Codes

Code	Class	Description
0	Success	No Command-Specific Errors
1-127		Undefined

10.21 Command #150: Set Transfer Function

This command enables or disables the 16 point lineariser.
See commands #138 & #139

Request Data Bytes

Byte	Format	Description
0	Enum	Linearisation: 0 = Linear 4 = Special Curve

Response Data Bytes

Byte	Format	Description
0	Enum	Linearisation: 0 = Linear 4 = Special Curve

Command-Specific Response Codes

Code	Class	Description
0	Success	No Command-Specific Errors
1		Undefined
2	Error	Invalid Selection
3	Error	Passed Parameter Too Large
4		Undefined
5	Error	Too Few Data Bytes Received
6	Error	Device Specific Command Error
7	Error	In Write Protect Mode
8-15		Undefined
16	Error	Access Restricted
17-35		Undefined
36	Error	Delayed Response Conflict
37-127		Undefined

10.22 Command #151: Read RTD Probe Connection

This command reads if a 3W RTD is in normal or differential mode..

Request Data Bytes

Byte	Format	Description
None		

Response Data Bytes

Byte	Format	Description
0	Enum	Probe Connection: 0 = Normal RTD or Other Probe Type 1 = Differential RTD

Command-Specific Response Codes

Code	Class	Description
0	Success	No Command-Specific Errors
1-127		Undefined

10.23 Command #152: Write RTD Probe Connection

This command sets normal or differential mode for a 3W RTD.

Note that it only applies if the probe type is set to 3W RTD using command #159

Request Data Bytes

Byte	Format	Description
0	Enum	Probe Connection: 0 = Normal 1 = Differential

Response Data Bytes

Byte	Format	Description
0	Enum	Probe Connection: 0 = Normal 1 = Differential

Command-Specific Response Codes

Code	Class	Description
0	Success	No Command-Specific Errors
1-2		Undefined
3	Error	Passed Parameter Too Large
4		Undefined
5	Error	Too Few Data Bytes Received
6		Device Specific Command Error
7	Error	In Write Protect Mode
8-15		Undefined
16	Error	Access Restricted
17-35		Undefined
36	Error	Delayed Response Conflict
37-127		Undefined

Note: An error is returned if the probe type is not 3W RTD

10.24 Command #153: Read Security Code

This command allows the internal menu security codes to be read.

Request Data Bytes

Byte	Format	Description
0	Enum	Security code: 0 = Menu code 1 = Alarm setpoint code

Response Data Bytes

Byte	Format	Description
0	Enum	Security code: 0 = Menu code 1 = Alarm setpoint code
1-4	Unsigned-8	Current 4 digit code in ASCII alpha-numeric Hex values

Command-Specific Response Codes

Code	Class	Description
0	Success	No Command-Specific Errors
1-2		Undefined
3	Error	Passed Parameter Too Large
4		Undefined
5	Error	Too Few Data Bytes Received
6-127		Undefined

Character Set

Code (Hex)	Code (Dec)	Character	Display
0x30	48	0	0
0x31	49	1	1
0x32	50	2	2
0x33	51	3	3
0x34	52	4	4
0x35	53	5	5
0x36	54	6	6
0x37	55	7	7
0x38	56	8	8
0x39	57	9	9
0x41	65	A	A
0x43	67	C	C
0x45	69	E	E
0x46	70	F	F
0x4A	74	J	J

Code (Hex)	Code (Dec)	Character	Display
0x4B	75	L	L
0x55	85	U	U
0x62	98	b	b
0x64	100	d	d
0x67	103	g	g
0x68	104	h	h
0x69	105	i	i
0x6E	110	n	n
0x6F	111	o	o
0x70	112	p	p
0x72	114	r	r
0x74	116	t	t
0x75	117	u	u
0x79	121	y	y

10.25 Command #154: Write Security Code

This command allows the internal menu security codes to be defined.

Note that only a limited set of characters are available (see command #153)

Request Data Bytes

Byte	Format	Description
0	Enum	Security code: 0 = Menu code 1 = Alarm setpoint code
1-4	Unsigned-8	4 Digit Code in ASCII alpha-numeric Hex values (Limited ASCII character set: See command #153)

Response Data Bytes

Byte	Format	Description
0	Enum	Security code: 0 = Menu code 1 = Alarm setpoint code
1-4	Unsigned-8	Current 4 digit code in ASCII alpha-numeric Hex values (Limited ASCII character set: See command #153)

Command-Specific Response Codes

Code	Class	Description
0	Success	No Command-Specific Errors
1-2		Undefined
3	Error	Passed Parameter Too Large
4		Undefined
5	Error	Too Few Data Bytes Received
6	Error	Device Specific Command Error
7	Error	In Write Protect Mode
8-15		Undefined
16	Error	Access Restricted
17-35		Undefined
36	Error	Delayed Response Conflict
37-127		Undefined

10.26 Command #155: Read Temperature Status

This command allows additional status information to be provided to host applications. This status is in addition to the Device Variable Status information provided with all Device Variables and Dynamic Variables.

Request Data Bytes

Byte	Format	Description
0	Unsigned-8	Device Variable Code: Always 0

Response Data Bytes

Byte	Format	Description
0	Bits	Device Variable Code: 0 = Temperature Device Variable Status (See Table 1) 1 = Temperature Status 0 (See Table 2)

Command-Specific Response Codes

Code	Class	Description
0	Success	No Command-Specific Errors
1		Undefined
2	Error	Invalid Selection
3-4		Undefined
5	Error	Too Few Data Bytes Received
6	Error	Device-Specific Command Error
7-15		Undefined
16	Error	Access Restricted
17	Error	Invalid Device Variable Index. The Device Variable does not exist in this field device
18		Undefined
19	Error	Device Variable index not allowed for this command
20-127		Undefined

10.27 Command #156: Read Temperature Configuration

This command reads the temperature configuration including: the type of probe (thermocouple, RTD, milli-volt, resistance); the number of wires used by the probe; and the temperature standard used for this measurement.

There are two widely used temperature standards: ITS-90, which this device uses, and IPTS-68. There is a difference of 0.01 to 0.1Kelvin between the two standards over the range from 10K to 700K. Please see relevant standards for details.

Request Data Bytes

Byte	Format	Description
0	Unsigned-8	Device Variable Code: Always 0

Response Data Bytes

Byte	Format	Description
0	Unsigned-8	Device Variable Code: Always 0
1	Enum	Probe Type (See Table 3)
2	Unsigned-8	Number Of Wires
3	Enum	Temperature Standard (See Table 6)

Command-Specific Response Codes

Code	Class	Description
0	Success	No Command-Specific Errors
1		Undefined
2	Error	Invalid Selection
3-4		Undefined
5	Error	Too Few Data Bytes Received
6	Error	Device-Specific Command Error
7-15		Undefined
16	Error	Access Restricted
17	Error	Invalid Device Variable Index. The Device Variable does not exist in this field device
18		Undefined
19	Error	Device Variable index not allowed for this command
20-127		Undefined

10.28 Command #157: Read Thermocouple Configuration

This command reads the additional installation and configuration information necessary when the connected temperature probe is a thermocouple. Most of the properties read by this command relate to Cold Junction Compensation. Cold-Junction Compensation is used to eliminate parasitic thermocouple effects. This is accomplished by using the reference-junction temperature to estimate the parasitic thermocouple thermoelectric voltage contributions.

Request Data Bytes

Byte	Format	Description
0	Unsigned-8	Device Variable Code: Always 0

Response Data Bytes

Byte	Format	Description
0	Unsigned-8	Device Variable Code: Always 0
1	Enum	Probe Connection (See Table 4)
2	Enum	Cold Junction Compensation Type (See Table 5)
3	Enum	Manual Cold Junction Compensation Temperature Units (refer to Common Tables Specification)
4-7	Float	Manual Cold Junction Compensation Temperature

Command-Specific Response Codes

Code	Class	Description
0	Success	No Command-Specific Errors
1		Undefined
2	Error	Invalid Selection
3-4		Undefined
5	Error	Too Few Data Bytes Received
6	Error	Device-Specific Command Error
7-15		Undefined
16	Error	Access Restricted
17	Error	Invalid Device Variable Index. The Device Variable does not exist in this field device
18		Undefined
19	Error	Device Variable index not allowed for this command
20-127		Undefined

10.29 Command #158: Read Callendar-Van Dusen Coefficients

Callendar-Van Dusen Coefficients allows an RTDs temperature response to be precisely described. If calibrated RTDs are supported, then this command must be supported. The Callendar-Van Dusen equation is:

$$R_T = R_0 (1 + AT + BT^2 - 100CT^3 + CT^4)$$

Where R_0 is the resistance at 0°C; T is the temperature (in degrees C); and R_T is the resistance at temperature T.

Request Data Bytes

Byte	Format	Description
0	Unsigned-8	Device Variable Code: Always 0

Response Data Bytes

Byte	Format	Description
0	Unsigned-8	Device Variable Code: Always 0
1-4	Float	CVD A
5-8	Float	CVD B
9-12	Float	CVD C
13-16	Float	CVD R_0

Command-Specific Response Codes

Code	Class	Description
0	Success	No Command-Specific Errors
1		Undefined
2	Error	Invalid Selection
3-4		Undefined
5	Error	Too Few Data Bytes Received
6	Error	Device-Specific Command Error
7-15		Undefined
16	Error	Access Restricted
17	Error	Invalid Device Variable Index. The Device Variable does not exist in this field device
18		Undefined
19	Error	Device Variable index not allowed for this command
20-127		Undefined

10.30 Command #159: Write Temperature Probe Type

This command writes the temperature probe type and number of wires connecting the probe to the field device.

Request Data Bytes

Byte	Format	Description
0	Unsigned-8	Device Variable Code: Always 0
1	Enum	Probe Type (See Table 3)
2	Unsigned-8	Number Of Wires

Response Data Bytes

Byte	Format	Description
0	Unsigned-8	Device Variable Code: Always 0
1	Enum	Probe Type (See Table 3)
2	Unsigned-8	Number Of Wires

Command-Specific Response Codes

Code	Class	Description
0	Success	No Command-Specific Errors
1		Undefined
2	Error	Invalid Selection
3-4		Undefined
5	Error	Too Few Data Bytes Received
6	Error	Device-Specific Command Error
7	Error	In Write Protect Mode
8		Undefined
9	Error	Unsupported Probe Type
10	Error	Invalid Number Of Wires
11-15		Undefined
16	Error	Access Restricted
17	Error	Invalid Device Variable Index. The Device Variable does not exist in this field device
18		Undefined
19	Error	Device Variable index not allowed for this command
20-31		Undefined
32		Busy (A Delayed Response Could Not Be Started)
33		Delayed Response Initiated
34		Delayed Response Running
35		Delayed Response Dead
36		Delayed Response Conflict
37-127		Undefined

10.31 Command #162: Select Cold Junction Compensation Type

This command allows the method of Cold Junction Compensation to be selected.

Request Data Bytes

Byte	Format	Description
0	Unsigned-8	Device Variable Code: Always 0
1	Enum	Cold Junction Compensation Type (See Table 5)

Response Data Bytes

Byte	Format	Description
0	Unsigned-8	Device Variable Code: Always 0
1	Enum	Cold Junction Compensation Type (See Table 5)

Command-Specific Response Codes

Code	Class	Description
0	Success	No Command-Specific Errors
1		Undefined
2	Error	Invalid Selection
3-4		Undefined
5	Error	Too Few Data Bytes Received
6	Error	Device-Specific Command Error
7	Error	In Write Protect Mode
8		Undefined
9	Error	Unsupported Probe Type
10-15		Undefined
16	Error	Access Restricted
17	Error	Invalid Device Variable Index. The Device Variable does not exist in this field device
18		Undefined
19	Error	Device Variable index not allowed for this command
20-31		Undefined
32		Busy (A Delayed Response Could Not Be Started)
33		Delayed Response Initiated
34		Delayed Response Running
35		Delayed Response Dead
36		Delayed Response Conflict
37-127		Undefined

10.32 Command #163: Write Manual Cold Junction Temperature

This command allows a manual CJC temperature to be written to the device.

Request Data Bytes

Byte	Format	Description
0	Unsigned-8	Device Variable Code: Always 0
1	Enum	Manual Cold Junction Compensation Temperature Units (refer to Common Tables Specification)
2-5	Float	Manual Cold Junction Compensation Temperature

Response Data Bytes

Byte	Format	Description
0	Unsigned-8	Device Variable Code: Always 0
1	Enum	Manual Cold Junction Compensation Temperature Units (refer to Common Tables Specification)
2-5	Float	Manual Cold Junction Compensation Temperature

Command-Specific Response Codes

Code	Class	Description
0	Success	No Command-Specific Errors
1		Undefined
2	Error	Invalid Selection
3-4		Undefined
5	Error	Too Few Data Bytes Received
6	Error	Device-Specific Command Error
7	Error	In Write Protect Mode
8		Undefined
9	Error	CJC Temperature too High
10	Error	CJC Temperature too Low
11-15		Undefined
16	Error	Access Restricted
17	Error	Invalid Device Variable Index. The Device Variable does not exist in this field device
18		Undefined
19	Error	Device Variable index not allowed for this command
20-31		Undefined
32		Busy (A Delayed Response Could Not Be Started)
33		Delayed Response Initiated
34		Delayed Response Running
35		Delayed Response Dead
36		Delayed Response Conflict
37-127		Undefined

10.33 Command #164: Write Manual Cold Junction Temperature

This command allows the Callendar-Van Dusen Coefficients for a calibrated RTD to be written to the field device.

Request Data Bytes

Byte	Format	Description
0	Unsigned-8	Device Variable Code: Always 0
1-4	Float	CVD A
5-8	Float	CVD B
9-12	Float	CVD C
13-16	Float	CVD R ₀

Response Data Bytes

Byte	Format	Description
0	Unsigned-8	Device Variable Code: Always 0
1-4	Float	CVD A
5-8	Float	CVD B
9-12	Float	CVD C
13-16	Float	CVD R ₀

Command-Specific Response Codes

Code	Class	Description
0	Success	No Command-Specific Errors
1		Undefined
2	Error	Invalid Selection
3-4		Undefined
5	Error	Too Few Data Bytes Received
6	Error	Device-Specific Command Error
7	Error	In Write Protect Mode
8		Undefined
9	Error	Coefficient A Invalid
10	Error	Coefficient B Invalid
11	Error	Coefficient C Invalid
12	Error	Coefficient R ₀ Invalid
13-15		Undefined
16	Error	Access Restricted
17	Error	Invalid Device Variable Index. The Device Variable does not exist in this field device
18		Undefined
19	Error	Device Variable index not allowed for this command
20-31		Undefined
32		Busy (A Delayed Response Could Not Be Started)
33		Delayed Response Initiated
34		Delayed Response Running
35		Delayed Response Dead
36		Delayed Response Conflict
37-127		Undefined

11 TABLES

Table 1. Temperature Device Variable Status

Code	Measurement
0xC0	Data Quality
0x40	More Device Family Status Available
0x01	Probe Break Detected

Table 2. Temperature Status 0

Code	Measurement
	Reserved

Table 3. Temperature Probe Types

Note: Unless otherwise indicated, thermocouple references are: IEC 584, NIST MN 175, DIN 43710, BS 4937, ANSI MC96.1, JIS C1602 and NF C42-321.

Code	Measurement
1	Ohms
3	Calibrated RTD (The Write Calendar-Van Dusen Coefficients Device Family Command must be supported to use this enumeration.)
12	RTD Pt 100 a=0.003850
15	RTD Pt 1000 a=0.003850
129	Milli-Volts
131	TC Type B (Pt30Rh-Pt6Rh) (IEC 584 etc.)
134	TC Type E (Ni10Cr-Cu45Ni) (IEC 584 etc.)
136	TC Type J (Fe-Cu45Ni) (IEC 584 etc.)
137	TC Type K (Ni10Cr-Ni5) (IEC 584 etc.)
138	TC Type N (Ni14CrSi-NiSi) (IEC 584 etc.)
139	TC Type R (Pt13Rh-Pt) (IEC 584 etc.)
140	TC Type S (Pt10Rh-Pt) (IEC 584 etc.)
141	TC Type T (Cu-Cu45Ni) (IEC 584 etc.)

Table 4. Thermocouple Probe Connections

Code	Probe Connection Type
1	Single. One probe is used to measure temperature
2	Differential. Two probes are connected in series to read differential temperature

Table 5. Thermocouple Cold Junction Compensation

Code	CJC Temperature Source
1	Internal CJC Temperature Measurement
2	External CJC Temperature Measurement
3	A Fixed CJC temperature value is supplied

Table 6. Temperature Standards

Code	CJC Temperature Standard
1	International Practical Temperature Scale of 1968 (IPTS-68)
2	International Temperature Scale of 1990 (ITS-90)

Unit Conversion

Internally, the transmitter uses degrees Celsius and other measurement units are derived from these values.

12. PERFORMANCE

12.1 Sampling Rates

Typical sampling rates are shown in the following table:

Primary temperature sensor sample	2 per second
Internal (cold-junction) sensor sample	Every 10 second
PV digital value calculation	2 per second
SV digital value calculation	Every 10 second
Analogue output update	2 per second

Note: Both temperature calculations use an equally-weighted running mean of typically the last 3 input values, variable with the damping settings.

12.2 Power-Up

On power up, the transmitter goes through a self-test procedure, which takes approximately 15 seconds. During this period, the device will not respond to HART commands, and the analogue output is set at 4.0mA.

When the self-test is satisfactorily completed, and the first measurement has been made, the PV and SV values are set, and the analogue output moves to a value representing the measurement. The slew rate of this movement is limited by the configured "damping time".

Only after the PV and SV are correctly set, will the device respond to HART commands.

If the self-test fails, all live measurement data (PV, SV, current and percent of range) are set to "Not A Number", and the analogue output is set to the configured malfunction-indicating current. The device will attempt to respond to HART commands.

Diagnostic mode is enabled, which can be cancelled by command #140

Fixed-current mode is cancelled by power loss.

12.3 Reset

Command 42 ("Device Reset") causes the device to reset its microprocessor. The resulting restart is identical to the normal power up sequence.

12.4 Self-Test

The self-test procedure is executed at power up, following Command 42 ("Device Reset"), or following Command 41 ("self-test"). This self-test takes about 2 seconds. During self-test following power-up or reset, the analogue output is set to 4.0mA and the device will not respond to HART commands.

During self-test following a self-test command, the analogue output is held at its last value; the device may respond normally to HART commands, or may return "busy" status.

Continuous self-testing is also part of the normal device operation. The same checks are made, but over a longer period, between measurement function cycles.

12.5 Command Response Times

Minimum	3ms
Typical	20ms
Maximum	100ms

The slave timeout of 256ms is adhered to.

12.6 Busy and Delayed-Response

The transmitter may respond with "busy" status if a further command is received while self-test is underway. It will also respond "busy" while the unit is showing local configuration menus.

Delayed-response is used where applicable.

12.7 Long Messages

The largest data field used is in the response to Command 138: 37 bytes.

12.8 Non-Volatile Memory

EEPROM is used to hold the device's configuration parameters. New data is written to this memory immediately on execution of a write command.

12.9 Modes

Fixed current mode is implemented, using command #40. This mode is cleared by power loss or reset. Diagnostic mode is implemented on power-up, and may be cleared using command #140.

12.10 Write Protection

Write-protection is provided, selected by common practice commands #72 and #76.

12.11 Damping

Damping is standard, affecting only PV, DV0 and the loop current signal.

ANNEX A. CAPABILITY CHECKLIST

Manufacturer, model and revision	BEKA associates BA47X/67X rev 1
Device type	Transmitter
HART revision	7.2
Device Description available	Yes
Number and type of sensors	2 (one external, one internal)
Number and type of actuators	0
Number and type of host side signals	1: 4/20mA analogue
Number of Device Variables	2
Number of Dynamic Variables	2
Mappable Dynamic Variables?	No
Number of common-practice commands	17
Number of device-specific commands	34
Bits of additional device status	24
Alternative operating modes?	No
Burst mode?	No
Write-protection?	Yes

ANNEX B. DEFAULT CONFIGURATION

Parameter	Default value
Lower Range Value	0
Upper Range Value	100
PV Units	degC
Sensor type	Pt100, $\alpha=0.385$
Number of wires	3
Damping time constant	1 second
Fault-indication	Up-scale
Write-protect	Disabled (i.e. write enabled)
Number of response preambles	5
Bargraph	Left Aligned Min = 0 Max = 100
Display	1 decimal place

ANNEX C. REVISION HISTORY

A1. Changes from Rev 1.0

No changes have been made from the initial release



**BEKA Associates
Old Charlton Road
Hitchin
Hertfordshire
SG5 2DA**

**Tel: +44 (0)1462 438301
Fax: +44 (0)1462 453971**

**Web: www.beka.co.uk
Email: support@beka.co.uk
or sales@beka.co.uk**